

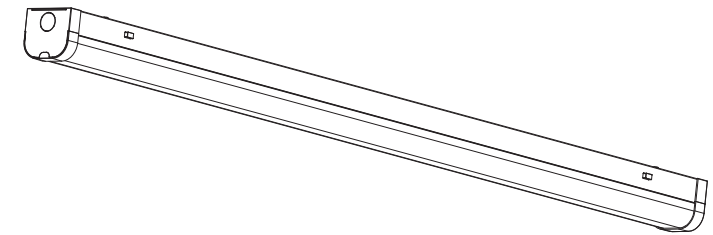

INSTALLATION MANUAL

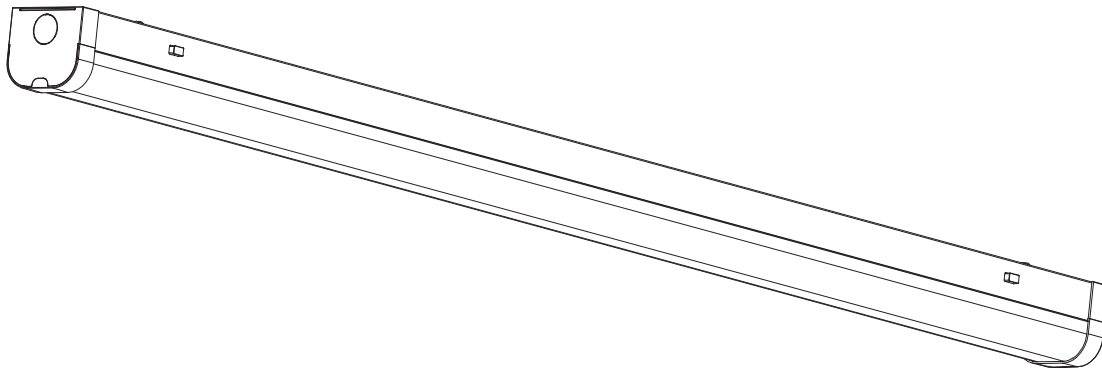

 1800 909 306

 nedlandsgroup.com.au

 sales@nedlandsgroup.com.au

20W / 40W LED

BATTEN

E-B20W-CC

E-B40W-CC

Important Safety Instructions

To ensure correct function and safety, please read and follow all instructions carefully before using the product:

1. Turn off power before installation or before doing any maintenance work.
2. Do not install any luminaire near the heat source.
3. For Indoor use only. Do not install this luminaires in damp or wet locations.
4. Do not exceed the nominal supply voltage or amperage ratings.
5. Dimmable version could be compatible with a wide range of recommended TRIAC dimmers.
6. All wiring and installation of the light fitting must adhere to local and national wiring rules.
7. Take care not to pull any electrical wires during unpacking as this may damage the connection.
8. Lay out all the components on a smooth surface and make sure there are no components missing before assembling.
9. To avoid injury or damage to the fitting, please ensure that power leads and screws are secure before connecting the power.
10. Please keep instructions for future reference.

Installation Procedure

Turn Off power supply before starting any installation. Read instructions & check you have all the tools & accessories to complete the installation correctly.

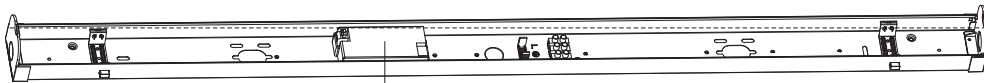

Mains LED Driver

Product drawing for Non-emergency function light

Step 1

Press the snap-on button and remove the cover.

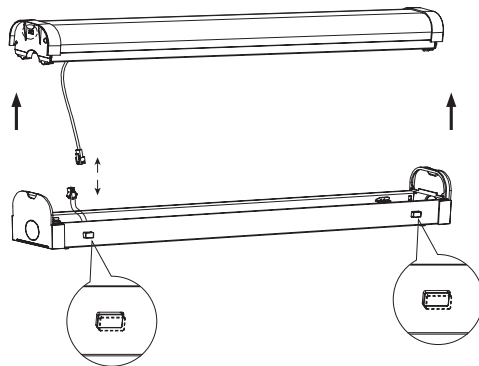

Step 2



Wiring diagram only for Non-emergency function light

Knock plastic anchor into ceiling. Connect the cable to terminal block. Fix the base to the ceiling.

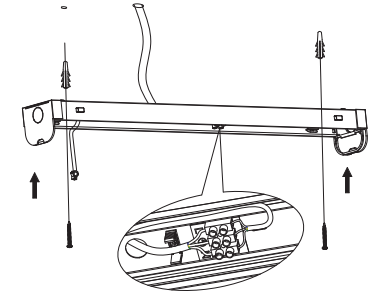

Step 3

Slide the preferred CCT, connect the DC plug. Press the snap-on button and fix the cover to the base.

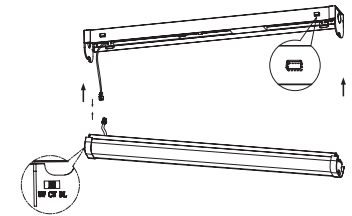

Step 4

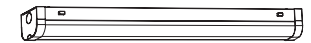

Installation complete.

* For non-user replaceable light sources:

"The light source contained in this luminaire shall only be replaced by the manufacturer or a similar qualified person."