



POWER-LITE®

Certainty at The Speed of Light



8W LED INTEGRAL DRIVER

DOWNLIGHT

ID8W-CC

The POWER-LITE® 8W LED Integral Downlight saves energy and costs as compared to standard halogen downlights. These come with a built-in LED driver with IC-4 insulation rating for easy install. This downlight includes the elimination of UV therefore insects will not be attracted to this light.



APPLICATIONS

Domestic | Retail

Commercial



1800 909 306

nedlandsgroup.com.au

sales@nedlandsgroup.com.au



POWER-LITE®

Certainty at The Speed of Light

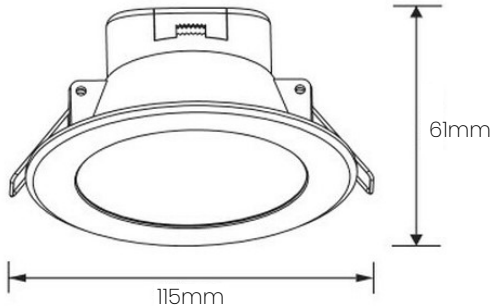

DIMENSIONS	(mm)
Cutout	90-95
Diameter	115
Height	61

Notes:

- Compatible with Clipsal C-Bus dimming systems
- IC-F / IC-4 rated downlights, can be covered and abutted with building materials which can be safely exposed to temperatures of up to 45°

LED Chip

Epistar 2835

Life Expectancy

40,000 hrs TM-21

Working Temp

-20°C to +45°C

CRI

>80

Efficacy

Up to 103lm/W

LED Driver

Dimmable

Integral

IC-4

Connection

1.2m Lead & Plug

or Hard wired installation

option

Carton Qty

30



8W



3 CCT



3000K
785lm



4000K
877lm



5700K
793lm



AC200-240V



White Frame
Colour

PRODUCT

8W LED INTEGRAL DRIVER
DOWNLIGHT

CODE

ID8W-CC

ACCESSORIES

OPTIONS

CODE

DOWNLIGHT RING



 Black

ID-BLACK



 Brushed
Chrome Finish
(304 Marine Grade
Stainless Steel)

ID-BC-R

140MM RETROFIT RING



 White

ID10W-RF-140



IP54



90°
Beam Angle



POWER-LITE®

Certainty at The Speed of Light

PHOTOMETRICS

ID8W-CC | 3000K

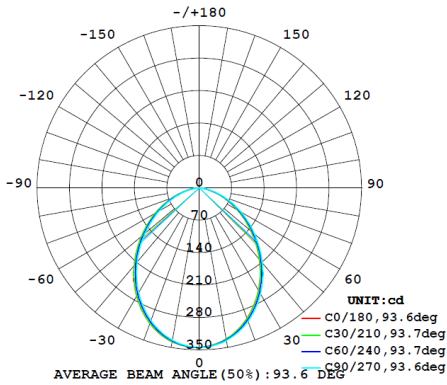

ID8W-CC | 4000K

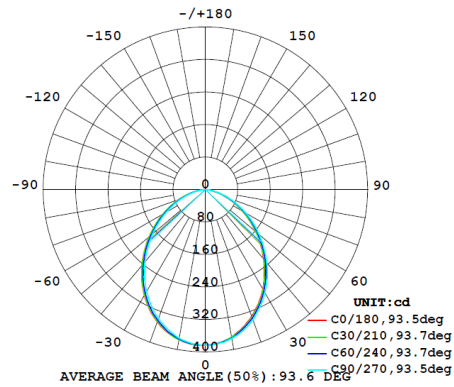

ID8W-CC | 5700K

