



POWER-LITE®

Certainty at The Speed of Light



LED SLIMLINE

FLOOD LIGHT

LED-SFL300W

The POWER-LITE™ LED Flood Light provides many benefits in addition to the substantial costs savings achieved through our LED technology.



ROHS

CE

APPLICATIONS

Commercial

Industrial



☎ 1800 909 306

🌐 nedlandsgroup.com.au

✉ sales@nedlandsgroup.com.au



POWER-LITE®

Certainty at The Speed of Light

DIMENSIONS (mm)

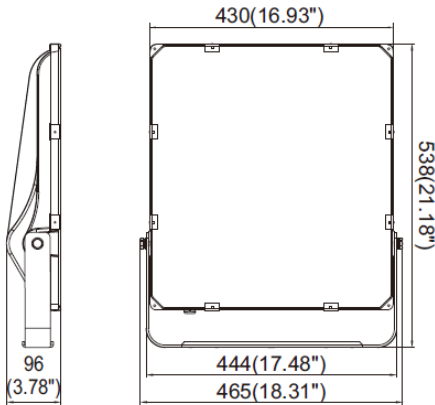

LED Chip
Philips

Life Expectancy
50,000 hrs L-70

Working Temp
-30°C to +50°C

CRI
>70

Power Factor
>0.98

Efficacy
123lm/W

LED Driver
Sosen Driver
Non-dimmable

Net Weight
8.2kg

Connection
1.5m Power Cable

Material
Aluminium ADC12

Replaces
600W

Carton Qty
1

300W

6500K
40,500lm

AC100-277V

Black Frame
Colour

PHOTOMETRICS

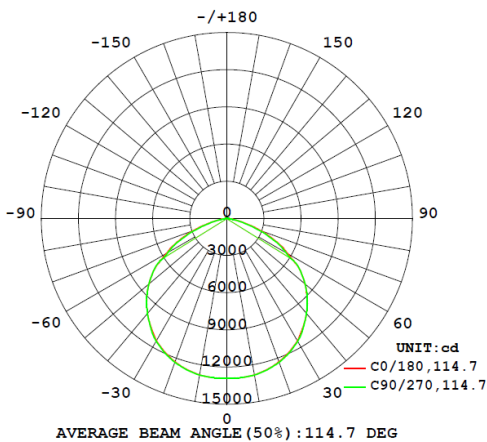

PRODUCT

LED SLIMLINE FLOOD LIGHT

CODE

LED-SFL300W

IP66

IK08

120°
Beam Angle



1800 909 306

nedlandsgroup.com.au

sales@nedlandsgroup.com.au